



YASS HIGH SCHOOL

We value respect, responsibility, safety and learning.

Principal: Linda Langton

Deputy Principals (Rel): Brendan Roberts & Ruth Riach

From the Principal

As we approach the end of Term 3, we prepare to farewell the Senior class of 2018. I would like to thank this exceptional group of young people for their leadership and contribution to Yass High. Our school captains Sam Sellars, Abi Grear, Hassan Alsamara and Tyahn Bell have carried out their duties throughout the year in a responsible and dignified manner, ably supported by their peers. We wish every Year 12 student great success in the upcoming HSC exams before they enter the next exciting phase of their life.

The leadership banner will pass to our newly elected leaders for 2018-2019: School Captains Thomas Rampton and Rhiannon Davis, and Vice Captains Matthew Johnson and Makayla Cameron. We look forward to working with them to continue building excellence in all we do at Yass High.

Thank you to the teaching and support staff for a busy yet productive term, and to all students who have worked towards their personal goals and achieved success in the many areas of their education. Many thanks also to parents and carers for supporting us as we share the school journey with your children.

I wish everyone a relaxed and well-deserved term break.



27 September 2018

Dress Up As Your Favourite Character Day

On Thursday 6th September, Yass High School dressed up as their favourite characters for a day. We raised \$760 for the Kids Cancer Council. Each student made a gold coin donation and the school had a sausage sizzle and a cake stall to raise additional funds. A DJ came to play, aka a fellow student Brandon Horne.

“An awesome effort and so great to see so many involved and helping as a school community,” said Mr Munn.

Lots of people dressed up, and a costume competition was held with prizes for individual, groups and teachers.

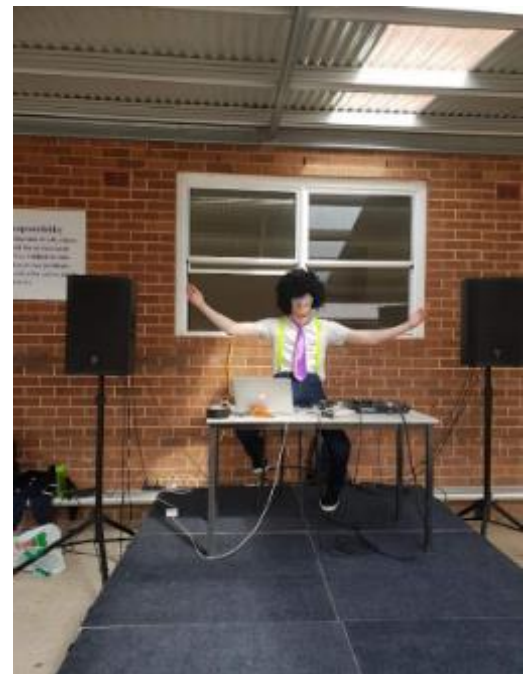

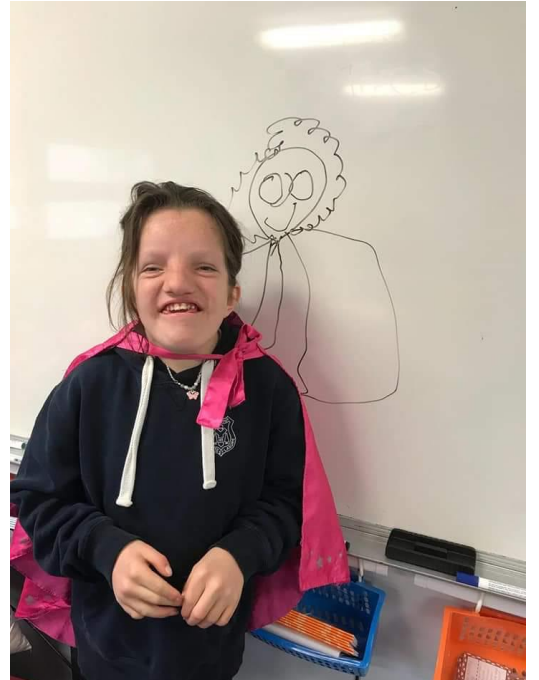

Daffodil Day

On Friday 24th of August, Miss Bills' Community students went around the school raising money for Cancer Council. This gave Yass High the opportunity to raise awareness for those who have been affected by cancer throughout the community of Yass. For Daffodil Day, the target goal was \$2,000, but this year we managed to raise \$2,400. Thanks to everyone who donated.



Afterwards, on Tuesday 28th of August, Miss Bills and Mr Harding had a haircut in the quad at lunch time. They had promised to do this if the school met their fundraising goal. Thanks to our shavers: Keeley Gear and Tamara Brooker!

Write a Book in a Day

On Monday, 20th August, ten Year 9 students spent a day in Room 10 at Yass High School to participate in the competition called 'Write a Book in a Day', supervised by Mr Munn and Ms Pinson. The team of young illustrators, authors, and editors consisted of Grace Bush, Samantha Sarah, Emily Fuller, Kaila Lymbery, Bridgette Edwards, Laella Ford, Nick Downey, Darcie O'Sullivan, Chrissie Davis, and Tahlia Pothan.



One of the competition's rules was to use specific words in the story, which had to be between 4000-5000 words and that the book itself had to be finished/published by 8pm that day. The primary characters, which were decided for them, were an art teacher, a great uncle and a penguin.

The setting was also chosen for them, a pet shop, and the story took 9.5 hours to complete.



'Margo Field, the local art teacher of Hamilton, strolled into her great Uncle Kevin's small country cottage. It was almost as ancient as him, clearly built in the 1940's. The driveway was short and rocky, and there was overgrown bottlebrush bushes and wilted roses in the garden alongside the driveway.' pg.1 of Treasure Hunt.

The story was titled 'Treasure Hunt', after the main character, a penguin called 'Treasure' was found after having been missing. All the illustrations in the story are hand-drawn, and all writing and editing were done by the students themselves, although teachers helped put the book together.

By Emily Fuller, Samantha Sarah, and Grace Bush

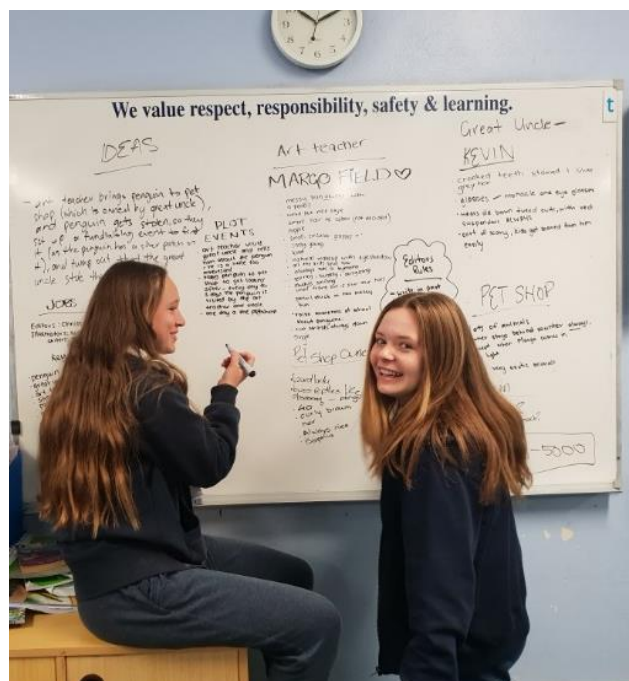

Bell Shakespeare Visit

Last week, Owen from the Bell Shakespeare Theatre Company visited Yass High to run a workshop with students from Years 7-9. The workshop got everyone up on their feet and moving, hurling Shakespearean insults at each other. It was fantastic at making the Bard's language seem much less daunting to understanding.

Owen also stayed behind in the evening to show teachers from across all faculties how to engage students in Shakespeare and drama. Thank you to Bell Shakespeare for giving Yass this fantastic opportunity.



Social Justice Group – Operation Christmas Child



Join the Social Justice Group to put together gift-filled shoeboxes to reach children in poverty. Bring in new gifts. Each child needs something to love, wear, play with, for school, something for personal hygiene and something special. We also need donations of \$10 to send them to the children overseas. Start collecting now and in October we will be packing the boxes. Collection points – box at front office and A-block teachers' office. Look out for us in the quad.

Ag Plot Calves



Pictured above are the Ag Plot dairy calves; their names are Frisky, Cleetus and Chocolate. They arrived at Yass High School on 6th August and left on the 24th August after being looked after by some of our caring students from our Year 9 Agriculture Class. The calves had a steady growth over the time they were here at our school. These calves helped our Year 9 students with the CCC (Calves Create Careers) program.

Y Tally

Congratulations to the following students who have received the most Ys in the last fortnight. You can pick up your canteen voucher from the front office – but make sure you do it before the next InTouch is published!

Yr 7: Angus Mackay

Yr 8: Lachlan Morris

Yr 9: Emily Preston

Yr 10: Matthew Doggett

Yr 11: Amy Bush and Claire Southwell

Year 12: Tyahn Bell, Eleanor Boehme and Anna Lynne

Year Eight Approaching Year Nine

We sat down and interviewed four Year Eight students: Finn Dunne, Kaydence Farnsworth, Kitty Duncan and Charlie Beck, about going into Year Nine next year.

What do you aspire to be when you leave Yass High?

Finn said he'd like to be a Paediatrician, with acting as his backup.

Kaydence would like to be a Vet.

Charlie said he wants to be a Nuclear Physicist.

Kitty (right) wants to be an Author and an Artist.

What electives would you like to choose for next year and why?

Kaydence expressed an interest in drama, and when we asked why, she answered, "Because I'm very dramatic."

Kitty said "Textiles. Because when I get older I would like to make my own stuff and not have to waste money."



How do you feel about Year Nine?

One word used was "invigorating".

What are you looking forward to in Year Nine?

"A second chance in the regional cross country," Finn answered.

The others said the new classes, having another chance to try better.

Are you ready for Year Nine? Are you prepared?

Kaydence shrugged, as she's not sure. Finn said he's not prepared and he's just going to show up on the first day and face it head on.

Charlie said he'll need one more term, and luckily for him, he has one.

Kitty confidently said yes, saying she's mentally prepared and ready to go.

Are you comfortable going into Year Nine? What are you going to miss about Year Eight?

All four students said they were comfortable going into Year Nine, and the only things they'll miss are some of the classes.

Year 9 Integrated Classes

Some Year 9 students in the InTouch team interviewed students in the other Integrated Learning classes. The other classes are focusing on creating a more sustainable environment at Yass High; here is what they had to say.

“We are planning to get rid of straws,” Corinne Green, Hannah Makin and Darcie O’Sullivan told us. This group is planning to get rid of straws all around Yass, because of the environmental impact they have. They are targeting our community and our school with this problem to encourage people to help solve it.

Max Hansson, Zach Enseleit and Ronin Packham are trying to recycle buildings by destroying them and reusing the parts. Their target audience is people who want to reshape a house using the same parts.

Chrissie Davis, Maeve Hughes and Zoe Wright are creating a website that lists eco-friendly cosmetic brands.

Miss Moss and her class have been busy making PowerPoints of how to make our school better. Some of the ideas include putting basket hoops around the bins so people can stop putting rubbish on the ground, re-doing the toilets to make them prettier, or painting the music room.

Anthony Chambers, Kaila Lymbery and Bridgette Edwards have been working on things to make the school better. They are planning to put cushions around the classrooms and increase accessibility to lockers. They will raise money to fund these ideas by hosting ‘mini fairs’ during school, costumes days and do more musicals and plays; their target audience is the students and teachers.



NSW Netball Cup – South Coast Final

Congratulations to the two Year 7-8 and one 9-10 girls' netball teams who competed at Goulburn in August in the NSW Cup Regional Finals. The girls played for a chance to play in Sydney in the State Finals. This competition is an all schools competition including private and public school teams. Five Yass High School teams competed at the local level and three of our teams won their spot to compete at the next level. The competition is very strong and Yass High had an impressive representation at the finals.



The 7-8 Gold girls narrowly missed their chance to play off for first place when a goal was controversially scored and awarded to the opposing team after the hooter had gone.

The 7-8 Red girls also narrowly missed the play off for first position when they lost in extra time to the first placed team in their pool.

Consequently a fun and very sportsmanlike game was played between the two Yass teams playing for 3rd and 4th respectively. A huge thanks must go to Trudy and Megan Polsen who umpired all day for these two teams and also umpired the 7-8 Grand final which was won by Kiama High School.

The 9-10 Gold girls also had a fantastic day coming 4th overall in a very competitive group of girls. The girls farewelled Renee Kemp in Year 10 as it was her last game in the NSW Cup. Renee has been an outstanding representative of Yass High School Netball not only as a player but also as a fabulous umpire and leader for the younger students.

All girls showed outstanding sportsmanship on the day and represented Yass High School proudly.

Thank you for all the parent support again this year, without your help with transport and coaching, the girls would not be able to participate in these carnivals.



Year 8 Shine

Year 8 girls who attend Shine every Thursday afternoon have been having a fantastic time learning about themselves and how they are valued. The girls participate in many activities including facials, nail treatments and collage making. These photos are the girls from Term 1 – stay tuned for photos from Term 2 & 3!



Jokes of the week

Q: What did the cat say when he went bankrupt?

A: I feel paw!

Q: Why was the cat sitting on the computer?

A: He was keeping an eye on the mouse!

Q: What do cats wear at night?

A: Paw-Jamas!

Q: Why did the Cat join the Red Cross?

A: She wanted to be a first-aid kit!

Solve the puzzle below! Find your way through!

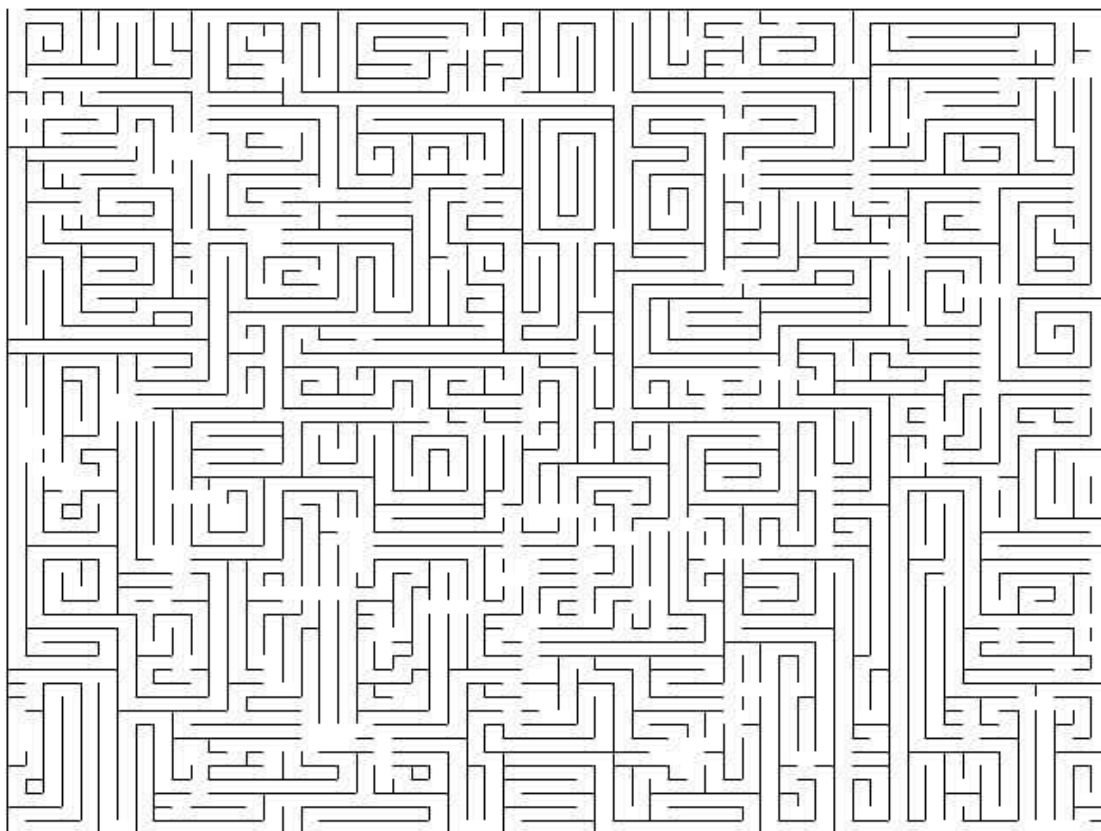

Last week's Sudoku answers...

5	1	2	4	8	6	9	3	7
3	8	6	7	1	9	2	4	5
4	7	9	3	5	2	6	1	8
2	9	3	5	4	1	7	8	6
6	5	8	9	7	3	4	2	1
1	4	7	6	2	8	5	9	3
8	6	4	2	3	7	1	5	9
9	2	1	8	6	5	3	7	4
7	3	5	1	9	4	8	6	2

Follow Your Dreams dance competition – Holly Fleming

By Liviul Lazar



What was your favourite part of FYDDC?

“The atmosphere is really nice, it gives you a boost like, ‘yes, this is a competition, we’re going to nail it.’ It's really quite positive”.

What styles of dance do you do at the competition?

“Jazz, Broadway Jazz, Lyrical, Ballet and student choreography”.

What are your favourite styles of dance?

“Contemporary, Lyrical and Expression”.

Have you made any friends at the competition?

“Yes, I have made a couple of friends and we meet up at Follow Your Dreams Dance Competition and other competitions”.

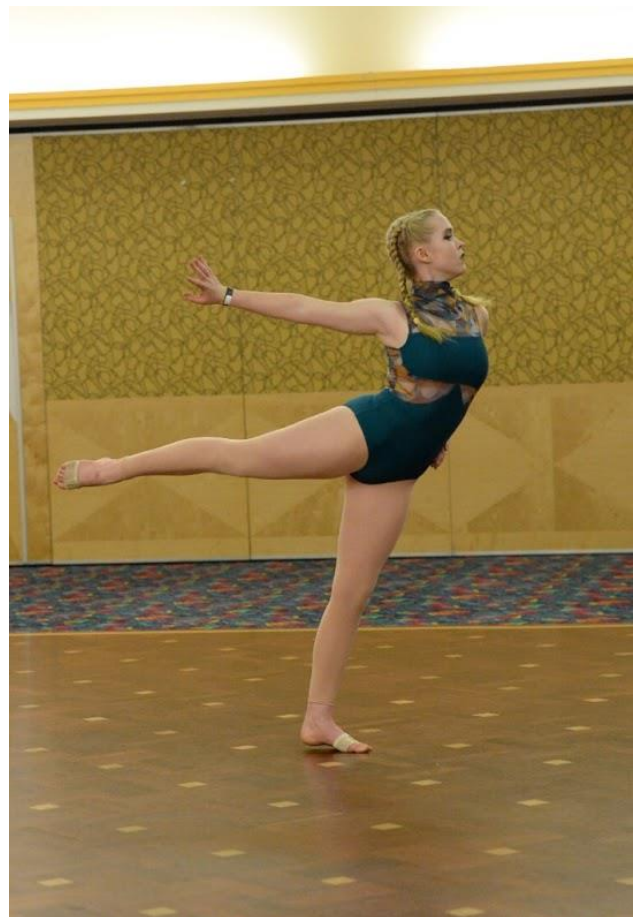

Congratulations to Holly on all her success; in the FYDDC, she placed in all six solos and finished 1st in her Contemporary performance. She finished the day as regional champion in her age group!

Tell Them From Me Survey

This year our school, like many other public schools in the state, will participate in a Department of Education initiative: the Tell Them From Me student feedback survey. The survey measures factors that are known to affect academic achievement and other student outcomes. The focus of the NSW-wide survey is on student wellbeing, engagement and effective teaching practices.

You may remember that our students also participated in a Tell Them From Me student survey in Term 1 this year. Asking students to complete the survey twice in one year allows us to identify trends in student responses as well as track engagement and motivation across the school year.

The survey is a great opportunity for our students to provide us with valuable and quick feedback on what they think about school life, how engaged they are with school and the different ways that teachers interact with them. More than 6,300 schools in Australia and around the world have used Tell Them From Me to survey 5.4 million students. Capturing the voices of our students will help improve how we do things at our school.

More information about the survey is available at: <http://surveys.cese.nsw.gov.au>

The survey is confidential and is conducted online; it will typically take less than 30 minutes to complete.

It will be administered during school hours between 27 August and 26 October. Participating in the survey is entirely voluntary.

If you do not want your child or children to participate, please inform the school. Copies of the form and FAQs are available from: <http://surveys.cese.nsw.gov.au/information-for-parents>.

The survey can be accessed by parents/community members at <http://nsw.tellthemfromme.com/7y7nv>

Faculty News – HSIE

Semester Two has been a busy one in the HSIE faculty, with many of our junior classes handing in fantastic assignments in History and Geography.

This term, Year 7 History have learnt about the cause and effects of the Black Death in Europe, Asia and Africa. Their assignment



required them to visually represent what life was like before, during and after the Black Death swept through the three continents.

Staff and students were impressed with the quality of these assignments, with some brilliant posters, dioramas and even a board game! Congratulations Year 7 on your hard work on this task.



Meanwhile, Year 9 Geography have been learning about the requirements of businesses and services in an ever-changing world.

To consider the growing and changing population of the Yass Valley, students were given a site to design a service to meet the future needs of the area. Councilman Chris Berry visited the school to talk to the students about the proposed site, along with the challenges facing our area over the next few decades.



Year 9 have done a fantastic job with their proposals, proposing ideas as diverse as cinemas, shopping malls, motels, arcades and recreation centres.

Landcare Links to Learning at Yass High School

Links to Learning teacher Deb Woods invited Kath McGuirk from Bowning-Bookham Landcare to undertake some environmental activities with Year 8 and Year 10 students in the recent week.

Year 10 students sowed native seed including chocolate lilly, saltbush, and red stem wattle. Students also attempted creating some Dusty Bell Correa cuttings. These cuttings and sown seed will be stored at the Yass Community Nursery to ensure that the plants are regularly watered, thinned and weeded as necessary.

These plants will be available for Links to Learning students or other interested student classes to plant around the grounds of the Yass High School in the first term of 2019. All of these plants will attract local birds to the school grounds.

Maths Problem of the Fortnight

Every InTouch, the Maths department boggle our minds with a new problem.

The first student to show Mr. Duncan their complete solution to this problem before school will be awarded a prize.

Year 7 & 8

Forks are sold in packets of 14. Knives are sold in packets of 8. If you want to buy the same number of forks and knives, what is the smallest amount of forks you can buy?

Year 9 & 10

(And those parents who want to compete for the prize!!!!)

A concrete support structure for a building is made up of a cylindrical base and a square prism as the main column. The cylindrical base is 1 m in diameter and 1 m high, and the square prism is 10 m long and sits on the cylindrical base as shown.

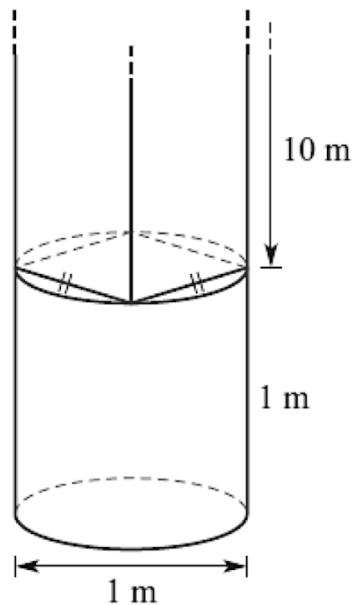

- Find the exact side length of the square base of the prism.
- Find the volume of the entire support structure, correct to 1 decimal place.

Interviews from past students of Yass High School

Sarah Rampton



What is it like not being in school?

“It’s pretty good. Sometimes it can be hard not having the same routine you’ve had for years though.”

What do you miss about High School?

“I’d say I miss the people I was there with the most.”

What are you doing right now?

“I’m working full time in child care, while I study.”

What is different about working than going to school?

“Work is very much doing things for other people compared to working hard for your own self.”

Do you have any friends from High School that you still talk to?

“I still talk to a lot of my friends from high school.”

What have you been doing for since you left High School?

“I have been studying and working.”

What was your favourite part about Yass High School?

Definitely the people.

Are there any skills that you learnt at Yass High School that you are using in life now?

English paragraph, essssssssssssssssay and story/ creative writing

Where are you living?

I am currently living at one of my co-workers house.



SUMMER FOOTBALL

Fun social football for all ages!

Friday evenings from Friday 2 November

Junior Comp: K-12

Senior Comp

Junior Players: \$50 / Senior Players: \$30

REGISTER ONLINE TODAY!

www.myfootballclub.com.au

REGISTRATIONS CLOSE: FRIDAY 12 OCTOBER

Enquiries

Juniors: Ed/Belinda 0411 866 133 or registrar@yassfc.com.au

Seniors: Paul 0450 441 975 or summer@yassfc.com.au



Coming Events

Date	Event
Thu 27 September	Year 12 Graduation Evening 6pm
Fri 28 September	Year 12 Final Assembly
Fri 28 September	Last Day Term 3
Mon 15 October	First Day Term 4
Thu 25 th October	Touch Carnival - Goulburn
Thu 25 th October – Sun 28 th October	Beef Bonanza
Mon 29 th October – Fri 2 nd November	Year 10 Driving Simulator
Thu 1 st November – Sat 3 rd November	Albury Show
Tue 6 th November	Pink Day
Fri 9 th November	Year 12 Formal
Mon 12 th November	Year 12 Sign Out Day
Mon 19 th November	Second Year 12 Sign Out Day
Tue 20 th November – Sun 25 th November	School Spectacular
<u>Click on the school website for the online calendar</u>	
<u>Remember assessment tasks dates due are available on school website assessment calendars</u>	